

EURASIAN JOURNAL OF BUSINESS AND MANAGEMENT

www.eurasianpublications.com

THE EFFECT OF PERSON-ORGANIZATION FIT ON THE ORGANIZATIONAL IDENTIFICATION: THE MEDIATING ROLE OF ORGANIZATIONAL ATTRACTIVENESS

Esra Cinar 

Baskent University, Turkey
E-mail: esrac@baskent.edu.tr

Abstract

The aim of this study was to investigate the mediator effect of organizational attractiveness on the relationship between organizational identification and person- organization (P-O) fit. To examine the research model, data were collected from 221 employees working in different sectors. By using structural equation model (SEM), the hypothesis of the research was analyzed. The results indicated that there was a significant and positive relationship between P-O fit and organizational identification and organizational attractiveness. Also, a positive and significant relationship was found between organizational attractiveness and organizational identification. Results of SEM showed that organizational attractiveness had a partial mediation effect on the relationship between P-O fit and organizational identification.

Keywords: Organizational Identification, Organizational Attractiveness, Person-Organization Fit

1. Introduction

Organizational behavior researchers view organizational identification as an important psychological phenomenon that leads to the positive organizational behaviors. Because organizational identification increases the job satisfaction of employees and contributes to the organizational success, this concept has long been the focus of organizational behavior researches (Ashforth and Mael, 1989) and has been the subject of many studies in terms of its antecedents and consequences. The person-organization (P-O) fit, which strengthens organizational identification and enables the organization to achieve its goals, is seen as an essential antecedent of identification. It is an important construct that leads to the emergence of behaviors that benefit the organization. It also has an important role in explaining the attitudes and behaviors in the workplace such as job satisfaction, job stress and intention to quit (Arbour *et al.* 2014).

High congruence increases organizational citizenship behavior and organizational commitment and decreases the intention to quit. Therefore, high P-O fit is a crucial construct that prevents the emergence of undesirable behaviors within the organization and thus ensures the efficient functioning of the organization.

P-O fit, which emphasizes the congruence between individual and organizational values, increases the identification of the employee with the organization (Carless, 2005). Because of

this, organizations put emphasis on P-O fit. Organizations willing to improve organizational identification of employees recruit people with high level of person-organization fit. The fit between individual and organizational values also increases organizational attractiveness (Carless, 2005; Turban and Keon, 1993). However, the elements that make the organization attractive for the individuals are related to the self-perception of the individual. For some individuals, P-O fit is one of the most important factors that make the organization attractive. In other words, the match between individual and organizational values render the organization attractive to employees (Tsui *et al.* 1997). Thus, it is possible that high P-O fit increases organizational attractiveness.

Based on these findings P-O fit may be an important predictor of organizational identification. High P-O fit may increase the organizational attractiveness, which in turn may increase the organizational identification. Therefore, this study aims to explore the possible mediating role of organizational attractiveness in the relationship between P-O fit and organizational identification.

2. Literature Review

2.1. Organizational Identification

Studies on different types of identification are present in the organizational literature, but most scholars focus more on organizational identification than other types of identification (Ashforth, 2016). The reason why this type of identification is focal point of many studies is that it is an essential psychological phenomenon indicating the connection between the individual and the organization (Edwards, 2005), showing why an individual act for the benefit of organization (Albert *et al.* 2000); and causing many cognitive and behavioral outcomes in the organizational context (Podnar, 2011). Besides, organizational identification allows satisfying psychological needs like self-esteem (George and Chattopadhyay, 2005), self-development and a sense of belonging (Sluss *et al.* 2012) and also gives a sense of security (Ashforth *et al.* 2013). As a result, organizational identification brings about positive perceptions towards the organization (Ashforth, 2016). Positive perceptions will result in behaviors in favor of the organization. For this reason, increasing employee identification with the organization can be one of the main goals of the organizations.

Drawing on social identity theory, organizational identification refers to the perception of belonging (Bhattacharya *et al.* 1995); an internalization of the behavior, value or goals of others (Cramer, 2001), the common values and goals existing between the individual and the organization (Reade, 2001). The link between social identity theory and organizational identification is based on the studies of Ashforth and Mael (1989) and Dutton *et al.* (1994). These researchers have emphasized the cognitive aspect of the organizational identification by defining organizational identification as a cognitive link between self-concept and perceived organizational identity (Dutton *et al.* 1994).

Social identity theory forms a basis for explaining the components and determinants of organizational identification as well as its situational and contextual variables (Van Dick, 2001). From the social identity perspective, organizational identification can be defined as the internalization of individual identity with a group / organization identity (Ashforth and Mael, 1989). When an individual perceives himself / herself as a member of a group / organization, identification processes emerge (Pratt, 1998) and the individual identity turns into a social identity (Hogg, 2014). With the activation of social identity, the members of the organization no longer appear as a unique individual but as a member of the organization (Voci, 2006).

Organizational identification has been the subject of many studies and has been examined in the context of its antecedents and consequences. There are several antecedents of organizational identification and one of the most important among them is person-organization fit. Organizational identification is used as a mechanism for explaining the P-O fit (Pratt, 1998).

2.2. Person-Organization Fit

Since P-O fit is a concept that provides the basis for the formation of important elements for the organization, such as job satisfaction, organizational citizenship behavior and business

performance, its importance is highlighted in organizational behavior literature (Liu *et al.* 2010). While high level of person-organization fit leads to positive organizational outcomes, low congruence results in negative outcomes such as intention to quit. For this reason, organizations recruit individuals with high level of adaptability or ability to adapt to organization (Astakhova, 2016). In this context; the reason for recruiting individuals who can adapt to organizational practices, norms and values and can create strong and stable links with the organization (Chatman, 1989) is actually to improve the compliance between individual and organization. This situation reveals the importance of P-O fit in recruitment processes (Carless, 2005).

P-O fit was developed from the Attraction-Selection-Attrition (ASA) model of Schneider (1987). The model states that different types of employees are affected by different types of organizations. Chatman (1989) emphasized the significance of “value” concept in P-O fit and defined the concept as the congruence between organizational norms and values, and individual values.

On the other hand, Carless (2005) defined the concept as the fit between individual and organizational qualities. This fit gives clues to organizations about to what extent individual values will change and to what extent they will adhere to organizational norms when they will be a member of the organization (Chatman, 1989). Low congruence can lead to a possible conflict between organizational and individual values. In this case, it is possible to mention three different options. First, individual values can change and adapt to organizational values, organizational values may change, or the individual may prefer to leave the organization (Chatman, 1989).

There are discussions about the conceptualization of P-O fit (Arbour *et al.* 2014), yet Kristof (1996) aims to provide a general definition by considering the supplementary / complementary fit, needs- supplies / demand-abilities perspectives. Supplementary fit is the similarity between basic individual characteristics and basic organizational characteristics (Muchinsky and Monahan, 1987; Vallabh and Singhal, 2014).

On the other hand, when the individual complements a feature incomplete in the organizational environment, it is considered as complementary fit (Muchinsky and Monahan, 1987). In other words, when the individual's abilities fulfill the missing side of the organization (Vallabh and Singhal, 2014), complementary fit takes place. According to the demand-ability approach; if the individual has the ability (knowledge, skill, energy) to meet the organizational demands (Kristof, 1996; Arbour *et al.* 2014), then the compliance will occur. With respect to the needs-supplies fit, when the organization satisfies the individual's needs, desires and preferences, the fit will take place (Kristof, 1996).

High P-O fit is regarded as the one of the strongest predictors of organizational identification (Dutton *et al.* 1994). For example, in a study that examined the relationship between organizational commitment, organizational identification, P-O fit and job satisfaction, a significant relationship was found between P-O fit and organizational identification (Sokmen and Biyik, 2016). In another study, it was found that an increase in the congruence between the values of the individual and the values of the organization will be led to an increase in the organizational identification (Ozcan, 2012). All these findings suggest that P-O fit has an effect on identification. Within the framework of these conceptual reasons, H₁ has been formed as:

H₁: There is a significant and positive relationship between P-O fit and organizational identification.

Organizations give importance to high fit between individual and organization. The match between individual values and organizational values positively affects the perception of the individuals, and they see the organization as a desirable place to work (Carless, 2005), which may increase the level of organizational attractiveness.

2.3. Organizational Attractiveness

Organizations strive to recruit talented employees and keep them in the organization (Joseph *et al.* 2014). In this context, employers try to make the organization attractive for possible talented employees so that individuals become a member of the organization. Organizational

attractiveness is related to the individual's affective and attitudinal thoughts regarding the organization's possible work positions (Highhouse *et al.* 2003).

The importance of the factors that make the organization attractive is related to the individual's self-perception. The self-concept has an impact on P-O fit and organizational attractiveness (Ehrhart and Ziegert, 2005). Therefore, it is highly possible that self-perception (O'Reilly *et al.* 1991) and the need for self-esteem are critical in individuals' job choices. For example, the need to compete to more people in order to be promoted in large organizations and more hierarchical structures makes these organizations more attractive for people with high self-esteem (Turban and Keon, 1993), so self-esteem appears to have a moderator effect on P-O fit and organizational attractiveness. Another factor that makes the organization attractive is the perception of difference. When the individual's social identity within the organization creates a perception of difference, they find these organizations more attractive (Dutton *et al.* 1994).

One of the most important factors that make the organization attractive for potential candidates is organizational prestige, which is one of the most influential premises of attractiveness. According to the social identity theory, the criteria of job seekers' thoughts regarding organizational prestige are related to the organization's characteristics and individual identity (Cable and Graham, 2000). In other words, in job selection and prestige assessments, some individuals consider the fit between individual identity and organizational characteristics (Cable and Graham, 2000). The reason for placing emphasis on organizational prestige and organizational attractiveness is actually the effort to create a positive social identity (Fisher and Wakefield, 1998).

Corporate social performance is another important issue that increases organizational prestige and makes the organization attractive. Organizations with high corporate social performance gain more prestige than organizations with low corporate social performance (Backhaus *et al.* 2002). This makes the organization more attractive for employees and positively affects their self-perception (Backhaus *et al.* 2002). From another perspective, individuals with internal locus of control find organizations that offer flexible benefit payments more attractive than individuals with external locus of control (Cable and Judge, 1994). On the other hand, organizations that offer a skill-based payment system seems to be more attractive to individuals with high self-efficacy than individuals with low self-efficacy (Cable and Judge, 1994). As seen, there are many factors that influence organizational attractiveness and the importance of these elements for the employee is highly relevant to the individual's self-perception.

Another important construct affecting the individual's self-perception of organizational attractiveness is P-O fit. According to the social identity theory, the fit between individual and the organization will result in positive thoughts about the organization, and this compliance will make the organization more attractive (Ehrhart and Ziegert, 2005). The overlap between the values and personality of the individual and the attributes of the organization will make the organization more attractive to the candidates (Umphress *et al.* 2007). The fit between them is likely to influence the attitudes and behaviors of individuals (Tsui *et al.* 1997). Several studies support these arguments. For instance, Rentsch and McEven (2002) and Turban (2001) showed that the fit between individual and organization affects organizational attractiveness. Consistent with this line of thinking, the second hypothesis of the research was developed as follows:

H₂: There is a significant and positive relationship between person-organization fit and organizational attractiveness.

2.4. The Mediator Effect of Organizational Attractiveness on the Association between Organizational Identification and P-O Fit

In the organizational behavior literature, while many studies supported the relationship between P-O fit and organizational identification and organizational attractiveness, there is no study examining the relationship between organizational identification and organizational attractiveness. Organizational identification and organizational attractiveness have several common predictors, one of which is P-O fit. As stated above, P-O fit is an important antecedent of organizational identification and organizational attractiveness.

Based on these implications, it is highly possible that there is a relationship between organizational identification and organizational attractiveness. It is assumed that high P-O fit will improve organizational attractiveness, and this will increase organizational identification. These inferences indicate organizational attractiveness may have a mediator impact on P-O fit and organizational identification. Based on these theoretical explanations the third and fourth hypothesis of the research was developed as follows:

H₃: There is a positive and significant relationship between organizational identification and organizational attractiveness.

H₄: Organizational attractiveness will have a mediator effect on the relationship between organizational identification and organizational attractiveness.

Figure 1 shows the research model of the study.

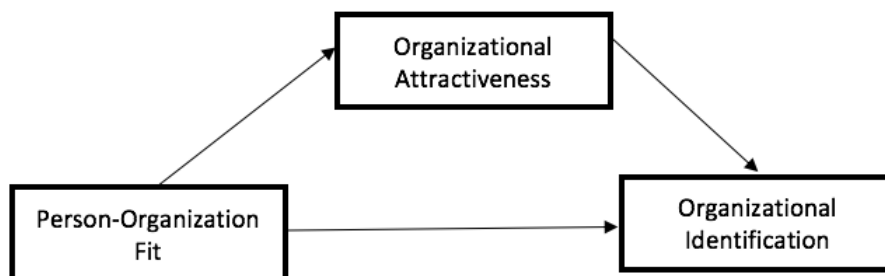

Figure 1. Research Model

3. Method

3.1. Participants and Data Collection

Data was collected in a random group of 221 employees working in different sectors including education and health. The sample was comprised of 47.5% (n=105) women and 52.5% (n=116) men. The age of the participants ranged from 24 to 74 years. The average age of participants was 37.84% (SD= 8.80). Participants had different educational backgrounds with PhD (55.7%), master (24.4%), college (17.2), high school (0.9%) and elementary (1.8%).

3.2. Measures

The data was collected by using undermentioned scales. AMOS 21.0 was used for the confirmatory factor analysis of the scales. To measure the Cronbach alpha of the scales, SPSS 17.0 was used.

3.2.1. Organizational Identification Scale

The organizational identification scale is originally developed by Mael and Ashforth (1992). It is translated into Turkish by Tak and Aydemir (2004). There are 6 items in the scale and it consists of items like: "When someone praises this employer, it feels like a personal compliment" and "My employer's successes are my successes." The extent to which participants agreed to the items on the scale was asked as 5-point Likert (1 = Strongly Disagree, 5 = Strongly Agree). High scores obtained from the scale indicate that organizational identification tendency is high. In this study, Cronbach alpha was found 0.85. As seen in Table 1, model fit indices indicated that the scale has an acceptable fit.

Table 1. Model Fit Indices of the Scale

	CMIN/df	GFI	CFI	RMSEA
Organizational Identification	3.30	0.96	0.96	0.078
Person- Organization Fit	0.75	0.99	1.00	0.02
Organizational Attractiveness	2.46	0.98	0.99	0.08

3.2.2. Organizational Attractiveness Scale

Highhouse *et al.* (2003) measured organizational attractiveness on a 5-point rating scales with five items like “For me, this company would be a good place to work” and “A job at this company is very appealing to me”. Originally, the scale has a three-dimensional construct which consists of 15 items. These three dimensions are named as general attractiveness, intentions to stay and prestige. In this study, only the five items given under general attractiveness was used. The scale was adapted to Turkish by Dural *et al.* (2014). Based on the reliability results, one item was removed from the scale. In this study, Cronbach alpha was measured as 0.79. Model fit indices shows that the scale had a good fit (see in Table 1).

3.2.3. Person- Organization Fit Scale

The questionnaires developed by Cable and DeRue (2002) and Netemeyer *et al.* (1997) were used to measure person-organization fit. The items in the scale were asked in 5-point Likert-type ranging from 1, “Absolutely Disagree” to 5, “Absolutely Agree”. There are five items on the scale. A sample item is “I think my personality is in a good compliance with this business.” In this study, Cronbach alpha was found 0.95. Table 1 points out the model fit indices and as seen in Table 1, the scale had an adequate fit.

4. Results

Means of the scales, standard deviations and correlations among the variables are analyzed by using SPSS 17.0. Results indicated the significant relationship between the variables. According to the results, organizational identification was positively correlated with P-O fit ($r= 0.512, p< 0.01$) and organizational attractiveness ($r= 0.258, p< 0.01$). P-O fit is significantly and positively correlated with organizational attractiveness ($r= 0.171, p< 0.05$). The mean of organizational identification, P-O fit and organizational attractiveness is relatively high. Correlation results and the means of the variables are displayed in Table 2.

Table 2. Correlations among variables

Factors	Mean	SD	1	2	3
1. Organizational Identification	3.26	0.94	1	0.512**	0.258**
2. Person-Organization Fit	3.50	1.49	0.512**	1	0.171*
3. Organizational Attractiveness	3.92	0.77	0.258**	0.171*	1

Note: ** $p< 0.01$, * $p< 0.05$, (N=221)

Then, Structural Equation Model (SEM) was performed to test the hypothesis of the study by using AMOS 21.0. First of all, SEM was conducted to examine the relationships between organizational identification, P-O fit and organizational attractiveness. According to the results, there was a significant relationship between organizational identification and P-O fit ($\beta= 0.52, p< 0.01$). In the second process, the impact of P-O fit on organizational attractiveness was analyzed. The results showed that P-O fit had a significant effect on organizational attractiveness ($\beta= 0.12, p< 0.01$). In the third step, the relationship between organizational identification and organizational attractiveness was examined. The findings revealed that organizational

attractiveness significantly affected the organizational identification ($\beta= 0.26, p <0.01$). The obtained results met the criteria for mediation analysis.

To be mentioned a mediator effect, a) there must be a statistically significant relationship between the dependent variable (organizational identification) and the independent variable (P-O fit) b) there must be statistically significant relationship between the independent variable (P-O fit) and the mediator variable (organizational attractiveness) c) there must be statistically significant relationship between the mediator variable and the dependent variable (Judd and Kenny, 1981).

Another SEM was performed for the overall model. After the inclusion of mediator variable (organizational attractiveness) into the analysis, the effect of independent variable (P-O fit) on dependent variable (organizational identification) was expected to decrease. The results revealed that there was a significant effect of P-O fit on organizational identification ($\beta= 0.49, p <0.01$). Hence, H₁ was supported. As understood from the results, the significant effect of P-O fit on organizational identification was decreased. It is also found that there was a significant relationship between P-O fit and organizational attractiveness ($\beta= 0.27, p <0.01$). Therefore, H₂ was supported. Also, a significant relationship was found between organizational identification and organizational attractiveness ($\beta= 0.13, p <0.01$). Hence, H₃ was supported. Then, the bootstrap procedure was performed to understand whether the decrease in the level of the relationship between P-O fit and organizational identification derived from the indirect effects of the P-O fit via the mediation of organizational attractiveness. The results indicated that P-O fit both directly affects the level of individual's organizational identification and indirectly affects it via the mediation of organizational attractiveness [$\beta=0.027, p < 0.05, \%90CI (0.079)$]. Therefore, H₄ was supported. It can be concluded that organizational attractiveness partially mediated the relationship between P-O fit and organizational identification. SEM for the overall model is presented in Figure 2. Model fit indices showed that the model had an adequate fit (CMIN/df=2.29; GFI= 0.90; CFI= 0.95; NFI=0.91).

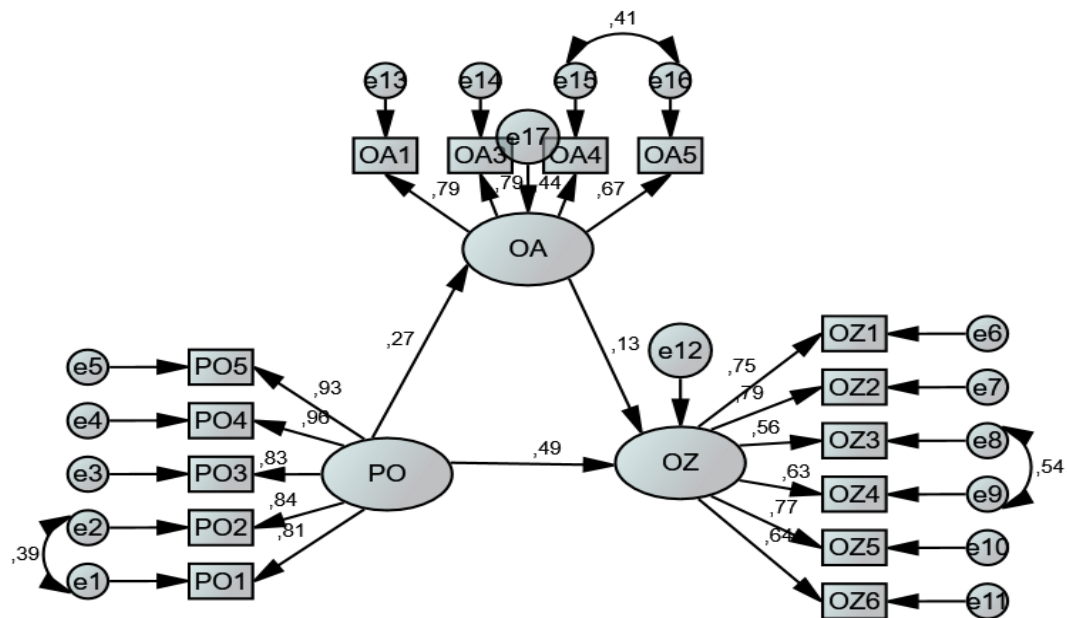

Figure 2. Structural Equation Model

5. Conclusion

The aim of this study was to explore the mediator effect of organizational attractiveness on the relationship between organizational identification and P-O fit. According to the literature, P-O fit is one of the most important predictors of organizational identification. Strong P-O fit empowers the organizational identification. Consistent with the organizational behavior literature in this study, a significant and positive relationship was found between P-O fit and organizational identification ($\beta = 0.52, p < 0.01$). Then, the mediation effect of organizational attractiveness on P-O fit and organizational identification was investigated by conducting SEM for the overall model. With the inclusion of the mediator variable (organizational attractiveness) into analysis as expected, a significant relationship between the organizational identification and P-O fit ($\beta = 0.49, p < 0.01$). Therefore, H_1 was supported. This finding is in line with organizational behavior literature and the previous research results (for example; Ozcan, 2012; Sokmen and Biyik, 2016). But as seen, there was a decrease in the effect of P-O fit on organizational identification. The results also revealed that, there was a significant relationship between P-O fit and organizational attractiveness ($\beta = 0.27, p < 0.01$). Hence, H_2 was supported. This result confirms previous studies' findings (for example; Rentsch and McEven, 2002; Turban, 2001).

Although in previous studies, organizational identification was studied in terms of its predictors and consequences, none of these studies considered the organizational attractiveness as a variable that might have an impact on organizational identification, so this study attempts to fill this research gap. One of the most important findings of this study was that the significant relationship between these variables was proved empirically ($\beta = 0.13, p < 0.01$). Therefore, H_3 was supported. At this point, this result contributes to the literature, showing the significant relationship between the variables. It can be concluded that organizational attractiveness is one of the antecedents of organizational identification. In other words, organizational attractiveness is one of the important factors that contributes to increase the level of organizational identification.

As mentioned above, there was a decrease in the effect of P-O fit on organizational identification. To understand whether the decrease in the level of the relationship between P-O fit and organizational identification stemmed from the indirect effects of the P-O fit via the mediation of organizational attractiveness, bootstrap procedure was conducted. The results showed that the indirect effect of P-O fit on organizational identification was significant ($\beta = 0.027, p < 0.05$). Hence, H_4 was supported. This result indicates both the direct and indirect effect of P-O fit on organizational identification via the mediation of organizational attractiveness. Therefore, the partial mediation effect of organizational attractiveness was found out in the study. The inclusion of mediating variable (organizational attractiveness) into the relationship between organizational identification and P-O fit may provide different perspectives for organizational behavior studies. The most basic finding obtained within the scope of this research was that it indicated the indirect effects of P-O fit, as well as the direct role of P-O fit and organizational attractiveness in explaining organizational identification.

The results of this study both contributes to the literature and guides to the managers. As mentioned above, one of the basic goals of organizations is to increase the employees' organizational identification. In addition to several predictors of organizational identification, organizational attractiveness is the reason for identifying with the organization. In this context, managers can use organizational attractiveness as a tool to ensure that employees are identified with the organization. Managers can increase the organizational attractiveness and employ qualified employees in the organization. In this case, managers need to focus on the elements that will make the organization attractive to employees. On the other hand, it is necessary to pay attention to the P-O fit in recruitment of employees because P-O fit increases organizational identification. Therefore, the high level of P-O fit increases organizational attractiveness, which reinforces organizational identification.

Like many studies, this study has some limitations. The finding of this study is limited to the sample where the data were collected. The results obtained from a different and larger sample will result in more generalizable results. On the other hand, the collection of data based on the self-report of the participants and the social desirability bias are the other limitations of the study.

References

- Albert, S., Ashforth, B. E., and Dutton, J. E., 2000. Organizational identity and identification: Charting new waters and building new bridges. *Academy of Management Review*, 25(1), pp. 13-17. <https://doi.org/10.5465/amr.2000.2791600>
- Arbour S., Kwantes C. T., Kraft J. M., and Boglarsky C. A., 2014. Person- organization fit: Using normative behaviors to predict workplace satisfaction, stress and intentions to stay. *Journal of Organizational Culture*, 18(1), pp. 41-64.
- Ashforth, B. E., and Mael, F., 1989. Social identity theory and the organization. *Academy of Management Review*, 14(1), pp. 20-39. <https://doi.org/10.5465/amr.1989.4278999>
- Ashforth, B. E., Joshi, M., Anand, V. ve O'Leary-Kelly, A. M., 2013. Extending the expanded model of organizational identification to occupations. *Journal of Applied Social Psychology*, 43(12), pp. 2426-2448. <https://doi.org/10.1111/jasp.12190>
- Ashforth, B. E., 2016. Distinguished scholar invited essay: exploring identity and identification in organizations: Time for some course corrections. *Journal of Leadership and Organizational Studies*, 23(4), pp. 361-373. <https://doi.org/10.1177/1548051816667897>
- Astakhova M. N., 2016. Explaining the effects of perceived person- supervision fit and person-organization fit on organizational commitment in the U.S. and Japan. *Journal of Business Research*, 69, pp. 956-963. <https://doi.org/10.1016/j.jbusres.2015.08.039>
- Backhaus K. B., Stone B. A. and Heiner K., 2002. Exploring the relationship between corporate social performance and employer attractiveness. *Business & Society*, 41(3), pp. 292-318. <https://doi.org/10.1177/0007650302041003003>
- Bhattacharya, C. B., Rao, H., and Glynn, M. A., 1995. Understanding the bond of identification: An investigation of its correlates among art museum members. *Journal of Marketing*, 59(4), pp. 46-57. <https://doi.org/10.1177/002224299505900404>
- Cable, D., and Judge, T. A., 1994. Pay preferences and job search decisions: A Person-Organization fit perspective. *Personnel Psychology*, 47(2), pp. 317-348. <https://doi.org/10.1111/j.1744-6570.1994.tb01727.x>
- Cable, D. M., and Graham, M. E., 2000. The determinants of job seekers' reputation perceptions. *Journal of organizational Behavior*, 21(8), pp. 929-947. [https://doi.org/10.1002/1099-1379\(200012\)21:8<929::AID-JOB63>3.0.CO;2-O](https://doi.org/10.1002/1099-1379(200012)21:8<929::AID-JOB63>3.0.CO;2-O)
- Cable, D. M., and DeRue, D. S., 2002. The convergent and discriminant validity of subjective fit perceptions. *Journal of Applied Psychology*, 87(5), pp. 875-884. <https://doi.org/10.1037/0021-9010.87.5.875>
- Carless, S. A., 2005. Person-job fit versus person- organization fit as predictors of organizational attraction and job acceptance intentions: A longitudinal study. *Journal of Occupational and Organizational Psychology*, 78(3), pp. 411-429. <https://doi.org/10.1348/096317905X25995>
- Chatman, J. A., 1989. Improving interactional organizational research: A model of person-organization fit, *Academy of Management Review*, 14(3), pp. 333-349. <https://doi.org/10.5465/amr.1989.4279063>
- Cramer, P., 2001. Identification and its relation to identity development. *Journal of Personality*, 69(5), pp. 667-688. <https://doi.org/10.1111/1467-6494.695159>
- Dural, S., Aslan, G., Alince, M. and Araza, A., 2014. Orgutsel cekicilik: Bir olcek uyarlama calismasi [Organizational attractiveness: A scale adaptation study]. *Doğuş Üniversitesi Dergisi*, 15(2), pp. 141-154. <https://doi.org/10.31671/dogus.2018.82>
- Dutton, J. E., Dukerich, J. M., and Harquail, C. V., 1994. Organizational images and member identification. *Administrative Science Quarterly*, 39, pp. 239-263. <https://doi.org/10.2307/2393235>
- Edwards, M. R., 2005. Organizational identification: A conceptual and operational review. *International Journal of Management Reviews*, 7(4), pp. 207-230. <https://doi.org/10.1111/j.1468-2370.2005.00114.x>
- Ehrhart, K. H., and Ziegert, J. C., 2005. Why are individuals attracted to organizations? *Journal of Management*, 31(6), pp. 901-919. <https://doi.org/10.1177/0149206305279759>

- Fisher, R. J. and Wakefield, K., 1998. Factors leading to group identification: A field study of winners and losers. *Psychology & Marketing*, 15 (1), pp. 23-40. [https://doi.org/10.1002/\(SICI\)1520-6793\(199801\)15:1<23::AID-MAR3>3.0.CO;2-P](https://doi.org/10.1002/(SICI)1520-6793(199801)15:1<23::AID-MAR3>3.0.CO;2-P)
- George, E., and Chattopadhyay, P., 2005. One foot in each camp: The dual identification of contract workers. *Administrative Science Quarterly*, 50(1), pp. 68-99. <https://doi.org/10.2189/asqu.2005.50.1.68>
- Highhouse, S., Lievens, F., and Sinar, E. F., 2003. Measuring attraction to organizations. *Educational and Psychological Measurement*, 63(6), pp. 986-1001. <https://doi.org/10.1177/0013164403258403>
- Hogg, M. A., 2014. From uncertainty to extremism: Social categorization and identity processes. *Current Directions in Psychological Science*, 23(5), pp. 338-342. <https://doi.org/10.1177/0963721414540168>
- Joseph, S., Sahu, S., and Khan, K., 2014. Organizational attractiveness as a predictor of employee retention. *IOSR Journal of Business and Management*, 16(9), pp. 41-44. <https://doi.org/10.9790/487X-16944144>
- Judd, C. M., and Kenny, D. A., 1981. Process analysis: Estimating mediation in treatment evaluations. *Evaluation review*, 5(5), pp. 602-619. <https://doi.org/10.1177/0193841X8100500502>
- Kristof, A. L., 1996. Person-Organization fit: An integrative review of its conceptualizations, measurement, and implications. *Personnel Psychology*, 49(1), pp. 1-49. <https://doi.org/10.1111/j.1744-6570.1996.tb01790.x>
- Liu, B., Liu, J. and Hu, J. 2010. Person-organization fit, job satisfaction, and turnover intention: An empirical study in the Chinese public sector. *Social Behavior and Personality*, 38(5), pp. 615-626. <https://doi.org/10.2224/sbp.2010.38.5.615>
- O'Reilly, C. A., Chatman J., and Caldwell D. F., 1991. People and organizational culture: A profile comparison approach to assessing person-organization fit. *Academy of Management Journal*, 34(3), pp. 487-516.
- Mael, F. A., and Ashforth, B. E., 1992. Alumni and their alma mater: A partial test of the reformulated model of organizational identification. *Journal of Organizational Behavior*, 13(2), pp. 103-123. <https://doi.org/10.1002/job.4030130202>
- Muchinsky, P. M., and Monahan, C. J., 1987. What is person-environment congruence? Supplementary versus complementary models of fit. *Journal of vocational behavior*, 31(3), pp. 268-277. [https://doi.org/10.1016/0001-8791\(87\)90043-1](https://doi.org/10.1016/0001-8791(87)90043-1)
- Netemeyer, R. G., J. Boles J. S., McKee D. O, and McMurrin R., 1997. An Investigation into the antecedents of organizational citizenship behaviors in a personal selling context. *Journal of Marketing* 61, pp. 85-98. <https://doi.org/10.1177/002224299706100306>
- Ozcan, H. U., 2012. Birey-orgut degerleri arasindaki uyumun orgutle ozdeslesme ile iliskisi [The relationship between P-O fit and organizational identification]. *Türk Psikoloji Yazıları*, 15(29), pp. 25-39.
- Podnar, K., 2011. Perceived external prestige, organizational identification and organizational commitment: An empirical examination. *Teorija in Praksa*, 48(6), pp. 1611-1627.
- Pratt, M. G., 1998. To be or not to be? Central questions in organizational identification. In: D. A. Whetten and P. C., Godfrey, eds. 1998. *Identity in organizations: Building theory through conversation*. Thousand Oaks, CA: Sage Publications. pp. 171-208. <https://doi.org/10.4135/9781452231495.n6>
- Reade, C., 2001. Antecedents of organizational identification in multinational corporations: Fostering psychological attachment to the local subsidiary and the global organization. *International Journal of Human Resource Management*, 12(8), pp. 1269-1291. <https://doi.org/10.1080/09585190110083794>
- Rentsch, J. R., and McEwen, A. H., 2002. Comparing personality characteristics, values and goals as antecedents of organizational attractiveness. *International Journal of Selection and Assessment*, 10(3), pp. 225-234. <https://doi.org/10.1111/1468-2389.00212>
- Schneider, B., 1987. The people make the place. *Personnel Psychology*, 44, pp. 763-792. <https://doi.org/10.1111/j.1744-6570.1987.tb00609.x>

- Sluss, D. M., Ployhart, R. E., Cobb, M. G., and Ashforth, B. E. 2012. Generalizing newcomers' relational and organizational identifications: Processes and prototypicality. *Academy of Management Journal*, 55(4), pp. 949-975. <https://doi.org/10.5465/amj.2010.0420>
- Sokmen, A., and Biyik, Y., 2016. Orgutsel baglilik, orgutsel ozdeslesme, kisi-orgut uyumu ve is tatmini iliskisi: Bilisim uzmanlarina yonelik bir arastirma. [The relationship between organizational commitment, organizational identification, person-organization fit, and job satisfaction: A research on IT specialists]. *Bilisim Teknolojileri Dergisi*, 9(2), pp. 221-227.
- Tak, B., and Aydemir, B. A., 2004. Orgutsel ozdeslesme uzerine iki gorgul calisma [Two empirical studies on organizational identification]. 12. Ulusal Yönetim ve Organizasyon Kongresi, Uludağ Üniversitesi, Bursa.
- Turban D. B., and Keon T. L. 1993. Organizational attractiveness: An interactionist perspective. *Journal of Applied Psychology*, 78(2), pp. 184-193. <https://doi.org/10.1037/0021-9010.78.2.184>
- Turban, D. B. 2001. Organizational attractiveness as an employer on college campuses: An examination of the applicant population. *Journal of Vocational Behavior*, 58(2), pp. 293–312. <https://doi.org/10.1006/jvbe.2000.1765>
- Tsui, A. S., Perace, J.L., Porter, L.W., and Tripoli, A.M., 1997. Alternative approaches to the employee-organization relationship. Does investment in employees pay off? *Academy of Management Journal*, 40, pp. 1089-1121. <https://doi.org/10.5465/256928>
- Umphress, E. E., Smith-Crowe, K., Brief, A. P., Dietz, J., and Watkins, M. B., 2007. When birds of a feather flock together and when they do not: Status composition, social dominance orientation, and organizational attractiveness. *Journal of Applied Psychology*, 92, pp. 396–409. <https://doi.org/10.1037/0021-9010.92.2.396>
- Vallabh P., and Singhal M., 2014. Workplace spirituality facilitation: A person- organization fit approach, *Journal of Human Values*, 20(2), pp. 193-207. <https://doi.org/10.1177/0971685814539407>
- Van Dick, R., 2001. Identification in organizational contexts: Linking theory and research from social and organizational psychology. *International Journal of Management Reviews*, 3(4), pp. 265-283. <https://doi.org/10.1111/1468-2370.00068>
- Voci, A., 2006. Relevance of social categories, depersonalization and group processes: Two field tests of self- categorization theory. *European Journal of Social Psychology*, 36, pp. 73-90. <https://doi.org/10.1002/ejsp.259>